

REF	DESC.
1	HANDLE
2	FLAT WASHER 1/2"
3	FLAT WASHER 1/2" (3X)
4	UPPER IDLER ROLLER
5	HEX BOLT 3/8"-16 X 4"
6	NUT 3/8"-16
6A	FLAT WASHER 3/8"
7	HEX BOLT 5/16"-18 X 1"
7A	FLAT WASHER 5/16"
8	UPPER IDLER ARM BRACKET
9	UPPER IDLER ARM
10	UPPER IDLER ARM BUSHING
11	UPPER IDLER ARM SPACER
12	FENDER WASHER 3/8"
13	HEX BOLT 1/2"-13 X 3-1/2"
14	TENSION O-RING (2X)

LP LINDGREN-PITMAN, INC.

LS3 / LS4 IDLER ARM ASSY.

SIZE	DWG. NO.	REV.
A		
SCALE:1:2	WEIGHT:	SHEET 1 OF 1

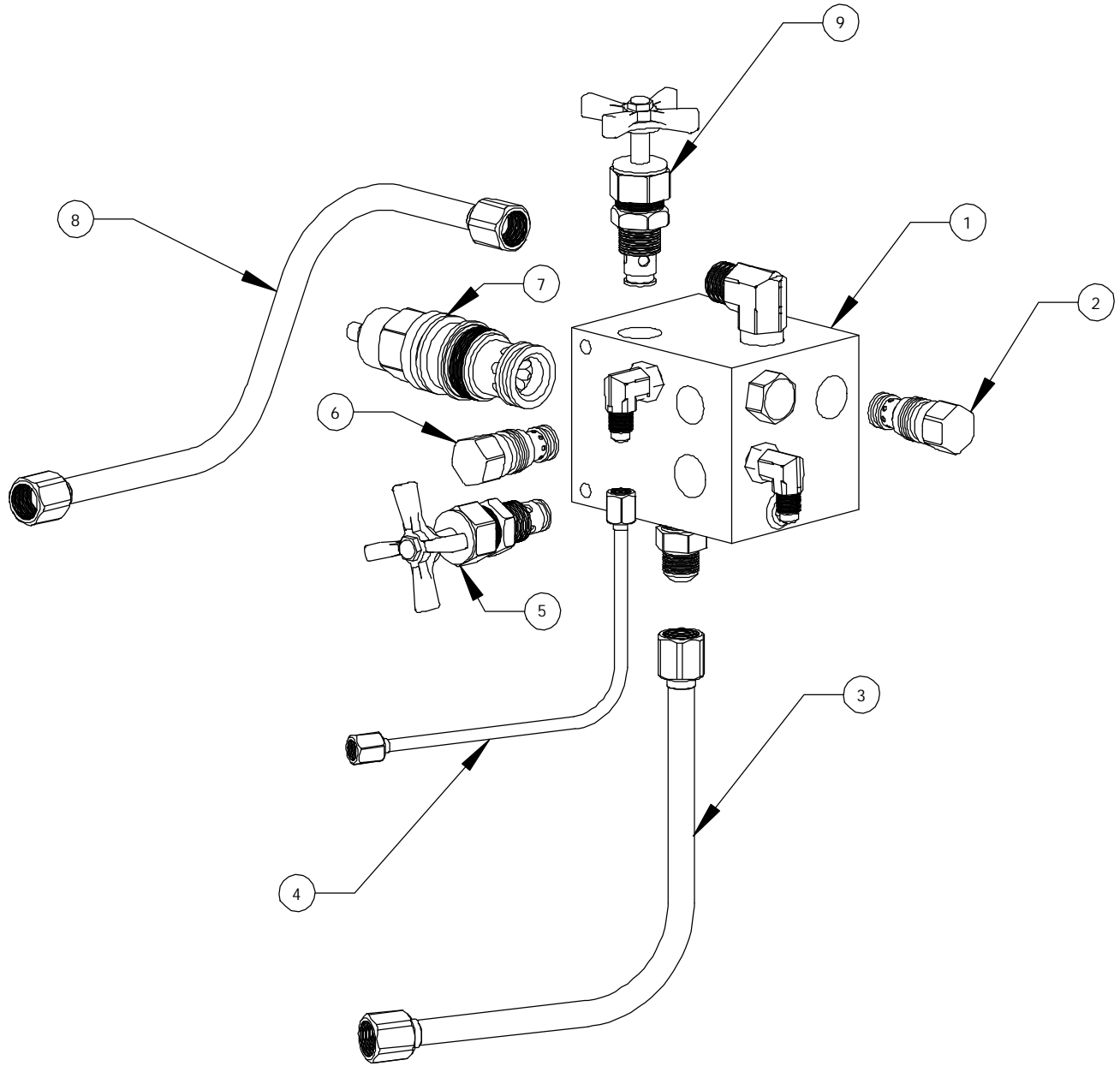

REF	DESC.
1	MANIFOLD ASSY.
2	CXDA-XAN - CHECK VALVE
3	1/2" TUBE - LOWER MANIFOLD
4	1/4" TUBE - MANIFOLD / MOTOR
5	SPEED CONTROL VALVE
6	CXDA-XEN - CHECK VALVE
7	RVBG-LCN - BYPASS RELIEF
8	1/2" TUBE - UPPER MANIFOLD
9	ON - OFF VALVE

LP LINDGREN-PITMAN, INC.

LS4 LINE SETTER MANIFOLD

SIZE	DWG. NO.	REV.
A		
SCALE:1:1	WEIGHT:	SHEET 1 OF 1